

Bond Graph Modeling and Simulation of Mechatronic Systems

Tufail Habib, Kjeld Nielsen, Kaj A Jørgensen,
Department of Mechanical and Manufacturing Engineering, Aalborg University
Fibigerstraede 16, DK- 9220 Aalborg
Denmark
habib@m-tech.aau.dk

Abstract:

One of the demanding steps in the design and development of Mechatronic systems is to develop the initial model to visualize the response of a system. The Bond Graph (BG) method is a graphical approach for the design of multidomain systems. That is ideal for visualizing the essential characteristics of a system.

This paper explores the BG method as a modeling approach to develop Mechatronic systems; a case study about the Radar Antenna pedestal drive system is comprehensively addressed. Flow of energy between different functional elements of the system and their causalities are analyzed. Furthermore, model is evaluated through state space equations and simulations are carried out in industrial software tool, such as 20-Sim.

Keywords: *Bond Graphs, Mechatronic systems, 20-sim tool.*

Introduction

Mechatronics is an interdisciplinary field of engineering, which characterizes the interconnections between mechanical engineering, electrical engineering and computer science such that these interconnections are the basis for designing successful products [1, 2, 3].

The design of mechatronic system requires a systematic development and use of software design tools. In addition, to domain specific engineering such as (mechanical, electrical/electronic, information technology and user interface) an integrated, concurrent engineering approach is required. The subsystems and components of the systems should not be developed independently without addressing the system integration, subsystem interaction and the intended operation of the overall system. Such an approach makes a mechatronic design more optimal than a conventional design.

When designing a mechatronic system, it is possible to design the mechanical equipment, before any of the control system design has been initiated. An obvious drawback of this sequential approach is the (predictable) lack of compatibility between the subsystems which results in additional efforts and (non conformance) costs to meet the specifications of the total (overall) system [5].

Because of the many varieties of designs, the modeling and simulation plays an important role, as well as saving the number of realized prototypes. Therefore, modeling of the heterogeneous components is required, using general modeling principles. At the system design stage of development, use is made of software-in-the-loop simulation (SiL), such that components and control algorithms are simulated on an arbitrary computer without real-time requirements to obtain, design specifications, dynamic requirements and performance

measures [6]. One of the key issues in the development of modern mechatronic systems is the strict integration of mechanical, control, electrical and electronic as well as software aspects from the beginning of the earliest design phases on, as shown in figure 1.

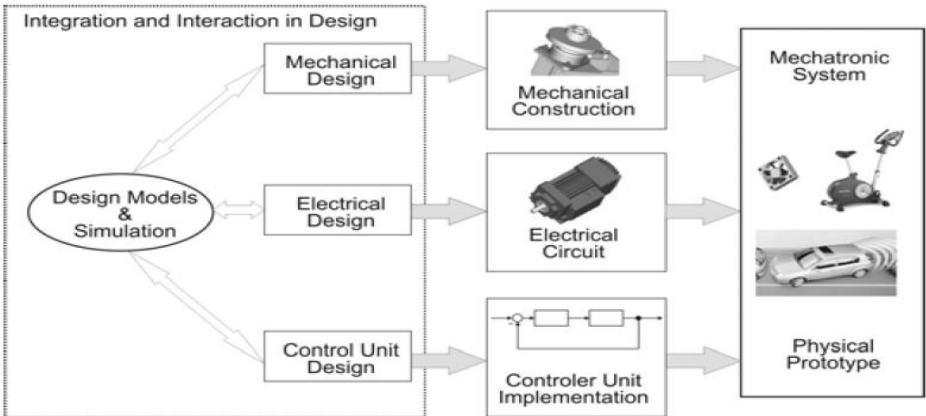

Fig1. Integration in mechatronic design [5]

For the design of a computer controlled system, it is crucial that the dynamics of systems that exchange power and energy in various forms be thoroughly understood, and methods for modeling, ways of analyzing systems and techniques to simulate the response of the systems, must be developed [7]. One of the main and most challenging steps in the design and analysis of a mechatronic system is to generate a computer based model [4].

Mechatronics offers potential for success in products but at the same time need special requirements on the development process especially at the initial development due to the integration of various domains, posing a high level of complexity. Since the interaction of mechanical, electronic and information processing components influence the behavior and form of the overall mechatronic system, modeling methods and simulation tools are needed for this purpose.

This paper, primarily describe the development of computer based model (of electromechanical pedestal drive system) through BG method, derivation of state space equations, and also its simulations and control in 20-Sim software.

Bond Graph Method

The BG is a graphical approach to modeling and simulation of multi-domain dynamic systems, in which component energy ports are connected by bonds that specify the transfer of energy between system components. Power, the rate of energy transport between components, is the universal currency of physical system [9].

Multidoamin systems (combined mechanical, electrical, pneumatic, hydraulic and thermal systems) can be modeled using a common notation, which is especially important in the design of mechatronic systems. In a typical mechatronic system, the dynamic behavior of the process (plant) is controlled to achieve the desired response. The following figure shows the main /subsystems components which are interconnected through the flow of either information or power. The high power energy transfers are shown by half arrows, whereas the information transfers are shown by full arrows [10].

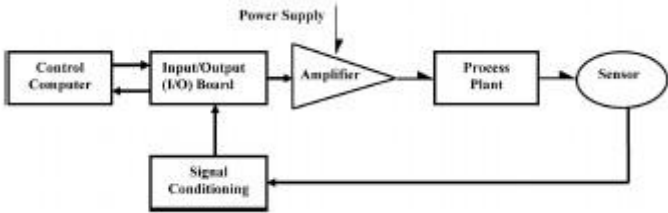

Fig2. Schematic diagram of a typical mechatronic system, with information and energy flows.

A bond graph simply consists of components linked by lines representing power bonds.

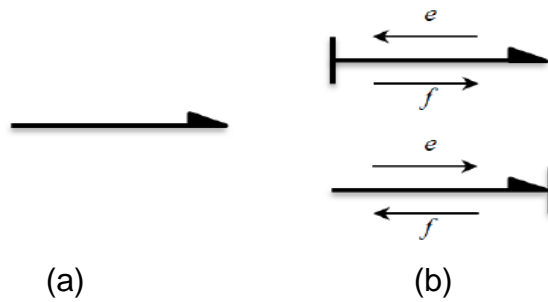

Fig 3-(a): Sign convention on the power bond. (b) Notation of effort and flow along with the indicated causality on the bond.

Table 1. Power and Energy variables in different energy domains along with effort and flow [8].

Energy domain	Effort (e)	Flow (f)	Momentum (p)	Displacement (q)
Electrical	Voltage [V]	Current [A]	Flux Linkage [Vs]	Charge [C]
Mechanical (translational)	Force [N]	Velocity [m/s]	Linear momentum [kgm/s]	Distance [m]
Mechanical (rotational)	Torque[Nm]	Angular velocity [rad/s]	Angular momentum [Nms]	Angle[rad]
Hydraulic	Pressure [Pa]	Volume flow rate [m ³ /s]	Pressure momentum [N/m ² s]	Volume[m ³]
Thermal	Temperature [k]	Entropy flow [J/s]	–	Entropy [J]
Magnetic	Magnetomotive force [A]	Flux rate [Wb/s]	–	Flux[Wb]

Causality is the most significant concept embedded in the Bond Graph in order to derive the state space equations. Causality is used to define which energy variables are input variables and which are output variables with respect to elements considered. It is represented by causal stroke, placed perpendicular to the bond at one of its ends. The causal stroke indicates the direction of the effort and flow. The direction of the causal stroke is independent of the power direction, which is shown in Figure 3-b.

The advantages of BG method is that it is equation based, multiple systems can be represented by the same set of equations and their modeling using a common notation, and causality concept is used to define the input and output energy variables. Similarly, BG obeys the laws of physics and the models can easily be simulated in software tools.

Case Study: Bond Graph construction of Antenna Drive system

Basic model of the drive system consist of a DC motor, gears and pedestal.

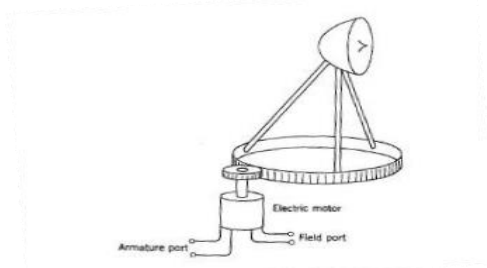

Fig 4. Schematic diagram for Radar antenna pedestal drive system.

The functional components of the drive system are connected by bonds, along with the effort and flow variables. For example in case of motor and shaft element the effort is torque and flow variable is angular velocity.



Fig 5. Word bond graph for the Antenna system. Where τ = torque, ω = angular velocity, v = voltage, i = current.

The bond graph model consists of an electrical and a mechanical part. Se is represented by an effort source in the form of input voltage. The current is common to the armature resistance R and to the inductance L . The inductance is represented by an “ I - element”, the resistance by an “ R -element”. Both of the elements are attached to 1 junction of the bond graph. The electromagnetic action is represented by an electric motor shown by the “ GY -element”, the rotor inertia and friction are modeled by the R and I -elements attached to the right 1 junction of the GY (motor). This 1 junction produces angular velocity when a voltage is applied. The “ C - element” represents the shaft stiffness and is attached to the “ 0 -junction”. Gears are used to represent the reduction in torque and speed. The gear train is modeled as transformer and the ratio of the number of teeth on each wheel becomes the transformer modulus “ m ” and modeled as “ TF -element”. Antenna load and friction are represented by me and R elements in 1 junction right to the TF element.

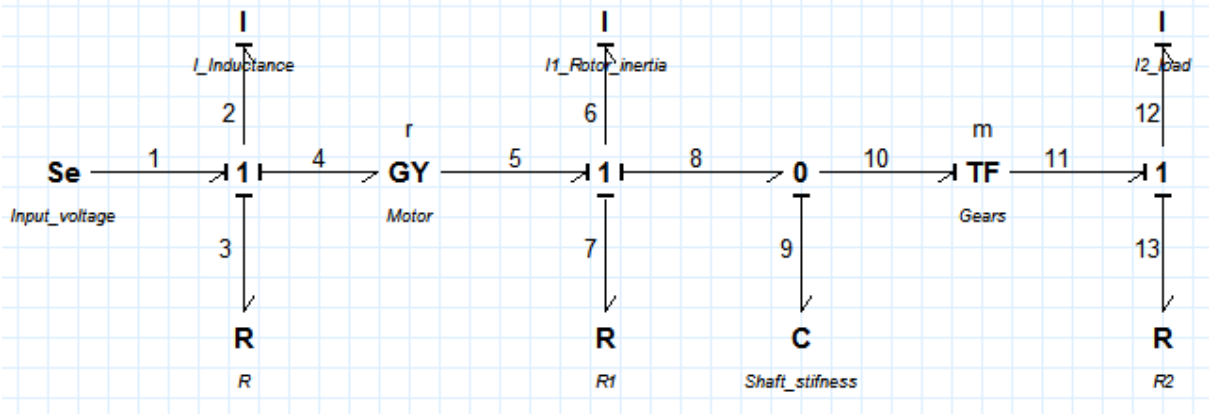

Fig 6 . Bond graph for the Antenna system
The BG method is useful to model the physical system. This represents the PLANT of a mechatronic system, including both electrical and mechanical components.

Causality analysis

Source Se specifies the effort in bond 1, in 1 junction one bond specifies the flow, and that is bond 2. The causal implications apply to bond 3 and 4.
At the next one junction, bond 6 is flow, the causality implications are, all other bonds 5, 7, 8 are efforts.
At the 0-junction, only one bond specifies effort, bond 9 is effort 10 becomes flow.
At the last 1 junction, bond 12 is flow; bond 11 and 13 becomes efforts.
This procedure also fulfils the requirements of integral causality to storage elements I and C .

State space equations

In the modeling of dynamic systems, state is a useful concept. The dynamics of a system, accompany the change of its state as time progress in those systems. State equations are derived from the bond graph shown in figure 6, the vector matrix equation can be written in the following form,

$$\dot{x} = Ax + Bu$$

Where A is the system matrix and B is the input matrix.

In this model four storage elements are found with integral causality, and there must be four state equations. There is only one source and the state vector x and the input vector u can be written as

$$x = \begin{bmatrix} p_2 \\ p_6 \\ q_9 \\ p_{12} \end{bmatrix} \text{ and } u = [S_e, 1] \quad (1)$$

Starting with the derivative of the first state variable p_2 ,

$$\dot{p}_2 = e_2 \quad (2)$$

Following the causal strokes in 1-junction, bond 1, 3 and 4 are effort variables while bond 2 is flow variable, this can be written as

$$e_2 = e_1 - e_3 - e_4 \quad (3)$$

$$e_1 = S_e \quad (4)$$

$$e_3 = R_3 f_3$$

$$e_3 = R_3 f_3 = R_3 f_2 = R_3 \frac{p_2}{I_2} \quad (5)$$

$$e_4 = r f_5 = r f_6 = r \frac{p_6}{I_6} \quad (6)$$

Substituting equations (4), (5), and (6) into equation (3), the state equation for p_2 becomes,

$$\dot{p}_2 = S_e - R_3 \frac{p_2}{I_2} - r \frac{p_6}{I_6} \quad (7)$$

The second state variable p_6 is equal to

$$\dot{p}_6 = e_5 - e_7 - e_8 \quad (8)$$

$$e_5 = r f_4 = r \frac{p_2}{I_2} \quad (9)$$

$$e_7 = R_7 f_7 = R_7 \frac{p_6}{I_6} \quad (10)$$

$$e_8 = \frac{p_6}{I_6} \quad (11)$$

Substituting equations (9), (10), and (11) into equation (8), the state equation for p_6 becomes,

$$\dot{p}_6 = r \frac{p_2}{I_2} - R_7 \frac{p_6}{I_6} - \frac{p_6}{I_6} \quad (12)$$

The third state variable q_9 is equal to

$$\dot{q}_9 = f_9 = f_8 - f_{10} \quad (13)$$

$$f_8 = \frac{p_6}{I_6} \quad (14)$$

$$f_{10} = \frac{q_9}{C_9} \quad (15)$$

Substituting equations (14) and (15) into (13), the state equation for q_9 is,

$$\dot{q}_9 = f_9 = \frac{p_6}{I_6} - \frac{q_9}{C_9} \quad (16)$$

The fourth state variable p_{12} is equal to

$$\dot{p}_{12} = e_{11} - e_{13} \quad (17)$$

$$e_{11} = \frac{1}{m} \frac{q_9}{c_9} \quad (18)$$

$$e_{13} = R_{12} \frac{p_{12}}{I_{12}} \quad (19)$$

Substituting equations (18) and (19) into (17), the state equation for p_{12} is,

$$\dot{p}_{12} = e_{11} - e_{13} = \frac{1}{m} \frac{q_9}{c_9} - R_{12} \frac{p_{12}}{I_{12}} \quad (20)$$

The four state equations are summarized in vector matrix form as

$$\begin{bmatrix} \dot{p}_2 \\ \dot{p}_6 \\ \dot{q}_9 \\ \dot{p}_{12} \end{bmatrix} = \begin{bmatrix} \frac{-R_3}{I_2} & \frac{-r}{I_6} & 0 & 0 \\ \frac{r}{I_2} & \frac{-1(R_7-1)}{I_6} & 0 & 0 \\ 0 & \frac{1}{I_6} & \frac{-1}{c_9} & 0 \\ 0 & 0 & \frac{1}{m c_9} & \frac{-R_{12}}{I_{12}} \end{bmatrix} \begin{bmatrix} p_2 \\ p_6 \\ q_9 \\ p_{12} \end{bmatrix} + \begin{bmatrix} 1 \\ 0 \\ 0 \\ 0 \end{bmatrix} [S e, 1] \quad (21)$$

The vector-matrix equation can be written in short form as

$$\dot{x} = Ax + Bu$$

Where x and u values are given by equation (1) and the system matrix A and input matrix B are written from equation (26) shown below,

$$A = \begin{bmatrix} \frac{-R_3}{I_2} & \frac{-r}{I_6} & 0 & 0 \\ \frac{r}{I_2} & \frac{-1(R_7-1)}{I_6} & 0 & 0 \\ 0 & \frac{1}{I_6} & \frac{-1}{c_9} & 0 \\ 0 & 0 & \frac{1}{m c_9} & \frac{-R_{12}}{I_{12}} \end{bmatrix}, \quad B = \begin{bmatrix} 1 \\ 0 \\ 0 \\ 0 \end{bmatrix}$$

The BG model is transformed through a systematic way into a mathematical model based on differential equations. These equations can be solved and simulated in the time domain by using numerical methods, or can be used to find the transfer function of the system. These differential equations govern the behavior of dynamic systems and can be used for the analysis and control of engineering systems.

Simulation Results

Several computer-based simulation tools are available for designing and simulating Bond Graphs. 20-Sim is a graphical modeling and simulation program which is suitable for generating and processing of dynamic systems, such as electrical, mechanical, and hydraulic systems or any combination of these in a user-friendly way. The software has been used for simulating the two approaches simultaneously; bond graph and electromechanical system.

After constructing BG of the antenna system, the response of the effort and flow variables of different components can be simulated. A unit step source is attached to the BG. Rotor is attached to second 1-junction, where all other bonds are in effort and rotor is in flow. Similarly the pedestal load is on last 1-junction having a flow variable, while the two bonds TF and R are in effort. Since flow in mechanical element is used for velocity, the respective angular velocities are simulated for both components. The speed is halved through the transformer which is acting as a gear train in this case study as shown in figure 7,

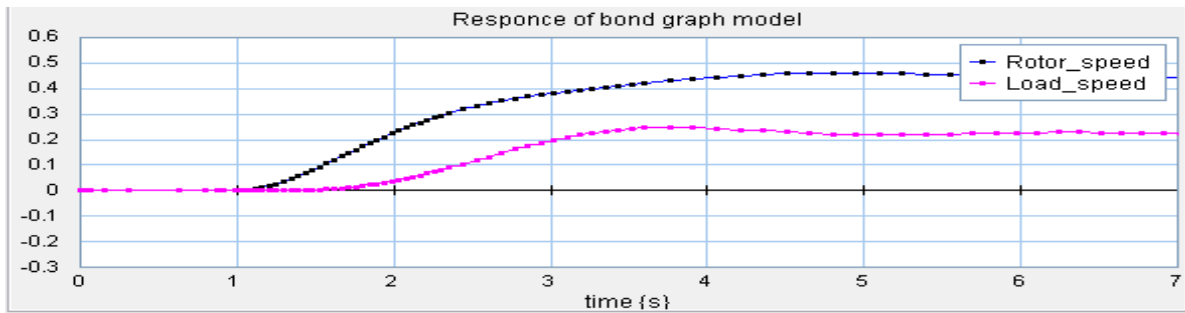

Fig 7. Response of the flow elements in BG.

In the zero junction of the BG, effort is represented on shaft while the other two bonds are in flow. The step response of the effort in shaft is shown in the following figure.

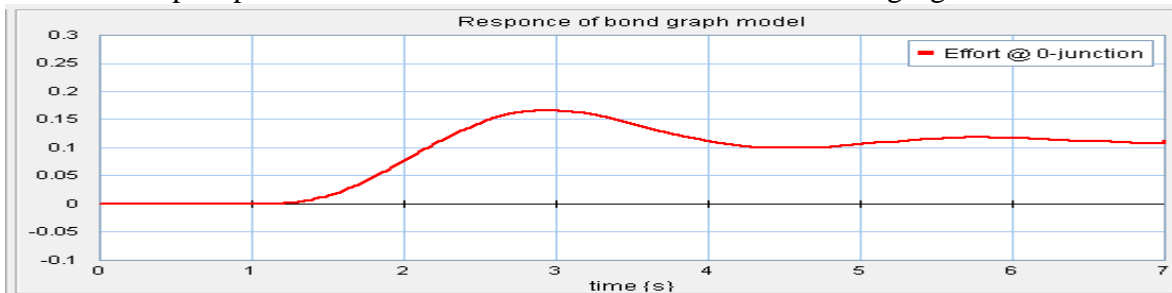

Fig 8. Response of the effort elements in BG.

Position control: Rotor position is controlled through a PID controller.

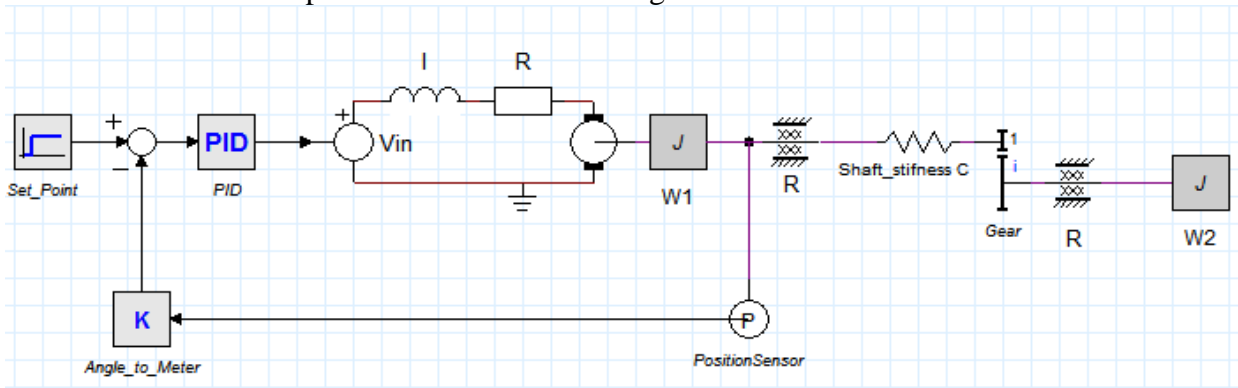

Fig 9 . Feedback control of the Antenna system

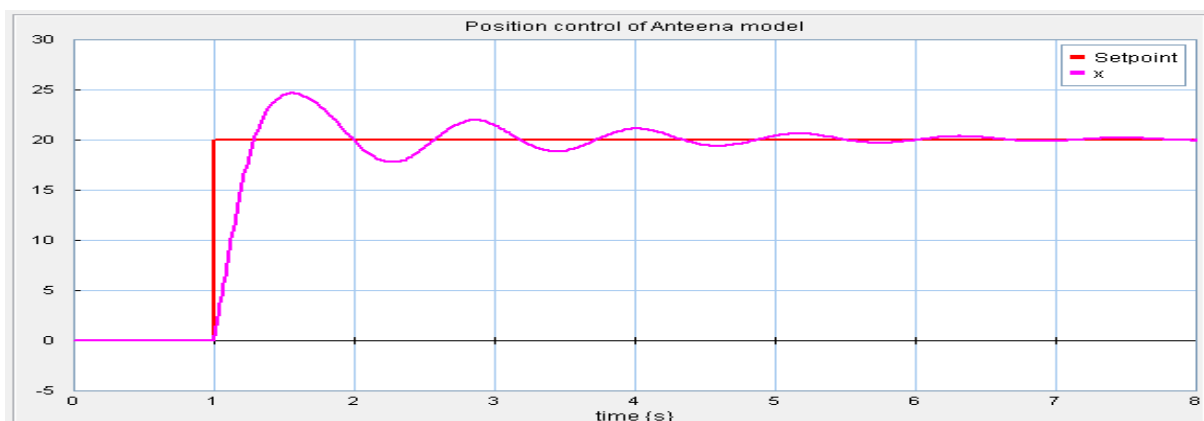

Fig10. Position control of the Antenna model

Discussion

At the system design level, modeling and simulation tools are being used, in order to get the overall response and behavior of the mechatronic system. Mechanical, electrical and software domains cannot be developed independently from each other at the beginning of the earliest design phases. Integrated, virtual and mathematical models are developed as they are less time consuming and are less expensive than physical prototypes. With the BG modeling, state equations representing the behavior of the system can be derived and can be easily simulated in software tools.

One of the key issues in the process of creating a physical device from scratch is the creation of computer based model and that of its control system. In BG, the physical system is build with power bonds which represent the power distribution amongst the individual elements, while the control part follows signal flows, as shown in the example of antenna system. More complex models such as internal combustion engine involving thermo-mechanical and hydro mechanical models can be developed. Many electrical and electromechanical systems contain magnetic circuits and devices, such as motor design, solenoid and transformer, can be modeled through this method.

After the desired response through BG models, C code generation and real time implementation, it is also possible to generate a number of controllers with varying parameters of the individual elements representing the physical system. These controllers are basically software that can be used for customization. These characteristics have also a great impact on manufacturing postponement because software, or even better, software parameters, can be changed late in the supply chain, ultimately at the customer site [11].

BG facilitates the development of software, and especially the control part, that is embedded in the computer of the mechatronic product. The functional view of the product can be as software module, which along with hardware modules is responsible for the overall control and capabilities of the product. This control can be digital, feedback and fault diagnosis. It can also enhance the adaptive and learning abilities of mechatronic products.

Conclusion

The modeling and design of mechatronic systems require a systematic development and use of software design tools. In these systems an integrated and concurrent approach is required in the presence of different types of interacting components from different engineering fields.

BG modeling is a graphical, domain free representation of systems by visualizing the essential characteristics through the analysis of the flow of energy. The BG of a dish antenna system is developed with causality analysis of all the interacting components in view of their respective effort and flows. The causality of the BG is used to derive the state space equations that can be used for dynamic analysis and derivation of transfer function.

Simulation of the system is carried in 20-Sim commercial software to get the desired response of the effort and flow components. Furthermore, the position control is implemented through the iconic diagram of the dish antenna system.

Acknowledgments

For this work, scientific support provided by Mechatronics department University of Agder, Norway and Controllab Products B.V. Netherlands.

References

- [1] Tomizuka, M. “Mechatronics: From the 20th to 21st century”, In Proceedings of the IFAC Conference on Mechatronic Systems, Darmstadt, Germany, 2000.
- [2] De Silva, C.W., “*Mechatronics – an integrated approach*”, CRC Press Boca Raton, London, New York, Washington DC, 2005.
- [3] Isermann, R.. *Mechatronic Systems. Fundamentals*, Springer Publishing Group, Berlin Heidelberg, Germany, 2005.
- [4] Granda, Jose. J, “The role of bond graph modeling and simulation in mechatronic systems”, *Mechatronics* 12(2002) 1271-1295.
- [5] Hehenberger. P, Egyed. A, Zeman .K.. “Consistency checking of Mechatronic design models“. Proceedings of the ASME 2010 International Design Engineering Technical Conferences & Computers and Information in Engineering Conference IDETC/CIE, August 15-18, 2010, Montreal, Quebec, Canada, 2010.
- [6] Isermann, R.,. “Mechatronic systems—Innovative products with embedded control”. *Control Engineering Practice* 16 (2008) 14–29, 2008.
- [7] Karnopp, D., Margolis, D, and Rosenberg, R., “System dynamics: modeling and simulation of mechatronics systems”, John Wiley & Sons, 2006.
- [8] Pedersen, E. and Engja, H. “Mathematical modeling and simulation of physical system”. Lecture Notes, NTNU, Trondheim, 2003.
- [9] Gawthrop, P. and Bevan, G. “Bond-graph modeling”.*IEEE Control Systems Magazine*, 2007. 27:24, 45. doi:10.1109/MCS.2007.338279.
- [10] Behbahani.S, De Silva.W, “Mechatronic modeling and Design”, *Mechatronic systems, Devices, Design, Operation and Monitoring*, CRC Press, 17-1-17-26,2007.
- [11] Jørgensen, K .A., “Customization and modeling applied to electronic and mechatronic products”. Nord design 2010, Gothenburg, Sweden, 24-27, 2010.